

Operating Instructions/Technical Data

for multi-purpose converter of type Multi-K4-MU

General instructions	These Operating Instructions are part of the scope of supply. They contain the information necessary in order to use the equipment for the purpose intended. They are intended for staff who have been trained or technical staff, who are familiar with the erection, assembly and commissioning of the product described here. If further information is required, it can be obtained from the address below.
Conformity	This equipment meets the requirements of the Directive of the Council of the European Community for harmonisation of the legal regulations of the Member States on electro-magnetic compatibility, EMC Directive 2004/108/EC, as well as the low voltage Directive 2006/95/EC.
Application	The measuring converter Multi-K4-MU serves for the simultaneous conversion and separation of current, voltage, frequency, active power, reactive power, apparent power and the power factor with sinusoidal shape of curve in 4 load independent direct current and direct voltage signals. The measurement is possible in alternating current systems and three or four wire three phase alternating current systems with equal or any other loading. The 11 measured quantities can be displayed, stored, configured over a USB interface on the PC and output in any chosen combination on the 4 double outputs. Two further outputs can be used as limit values or impulse outputs. The switching status of the limit value outputs or impulse outputs is indicated over two LED's.
Function	The parameters to be measured pass over current and voltage converters to a 22 bit analogue digital converter with a sampling frequency of >500 kSPS and from there to a microcontroller which calculates the values required for the outputs from the values picked up. The output values for current and voltage are effective values. The frequency is calculated from the period of the voltage signal of the phase L1. The active power is the sum of the products of the sampled values of current and voltage of the three phases. As the sum of the reactive power of the three phases the product of the sampled values of current and the voltage signal displaced by 90° is used for the calculation. The apparent power is the sum of the products from the three effective values of current and voltage. The power factor is calculated from the complete apparent power and the complete active power. The output amplifier delivers load independent direct current and direct voltage signals. The output signals are galvanically separated from the input signals and the auxiliary voltage, but they are connected to one another through a common earthing wire. The outputs are no load and short circuit proof. The two limit values or impulse outputs are galvanically separated from all inputs and outputs and from the auxiliary voltage. An auxiliary voltage is required.

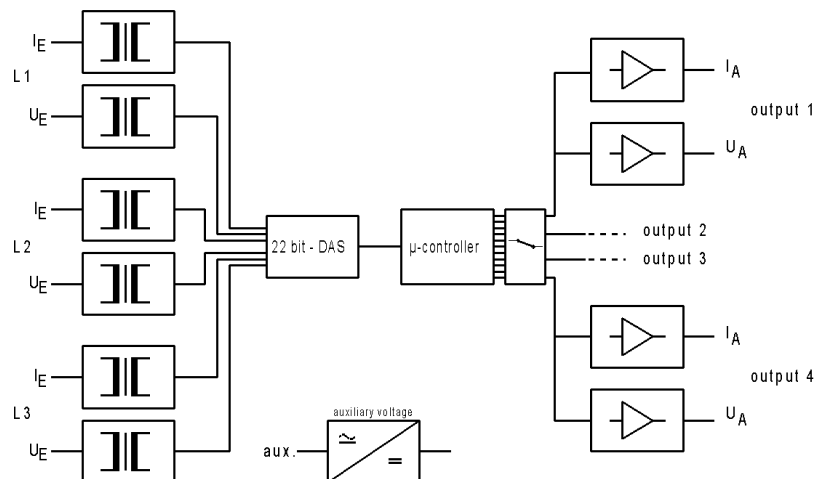

Technical data

Input

Input parameters	alternating current, alternating voltage, frequency, active power, reactive power, apparent power and power factor in alternating current systems, four wire and three wire three phase alternating current systems with equal or any other loading, one or two sided energy direction, configurable
Nominal current	2 A and 6 A
Current range	0.3 – 10 A, configurable
Nominal voltage	100 V to 750 V
Voltage range	40 – 750 V, configurable
Nominal frequency	50 Hz
Frequency range	40 – 80 Hz
Own consumption	for each current path 0.06 VA at 1 A, 0.3 VA at 5 A for each voltage path 0.02 VA at 100 V, 1 VA at 750 V
Continuous overload	voltage max 750 V, current max. 12 A
Surge overloading	voltage 1000 V 1 sec., current 240 A 1 sec.

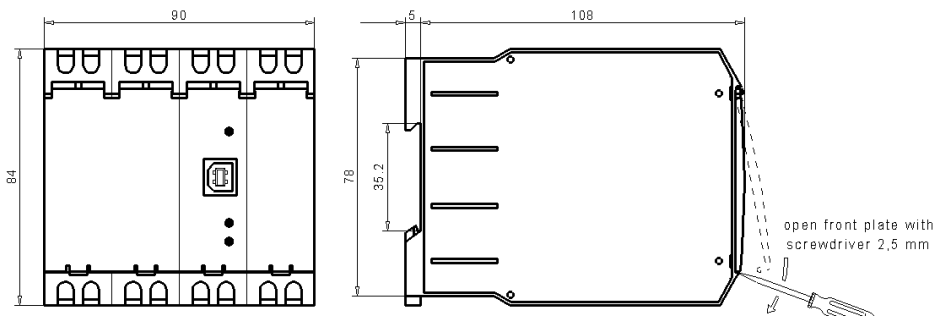

MÜLLER + ZIEGLER GmbH & Co. KG, Industriestr. 23, D-91710 Gunzenhausen
 Tel. +49 (0) 98 31.50 04 0, Fax +49 (0) 98 31.50 04 20
<http://www.mueller-ziegler.de> , e-mail: info@mueller-ziegler.de

Indicators	green LED red LED's G1 and G2	functional test (fast flashing → equipment functions correctly) shine if limit values G1 or G2 are reached and/or at impulse output
Analogue outputs	Output parameters Nominal value current Nominal load, current Nominal value voltage Nominal load, voltage Polarity	load independent direct current and load independent direct voltage with 12 bit resolution, with simultaneous use of both outputs the voltage output may be loaded with a maximum of 1 mA 0 – 10 mA, 0 – 20 mA, 4 – 20 mA, configurable < 500 Ohm 0 – 5 V, 0 – 10 V, 2 – 10 V, configurable > 750 Ohm 4 x unipolar or bipolar, configurable
Limit value and impulse outputs	Type Operating voltage Operating current Length of impulse Hysteresis Accuracy Note: The weighting of the impulse is divided by the transmission ratio (K_N) of the current and voltage converter used.	Open collector, (NPN transistor) 5-24 V DC, max. 30 V DC max. 40 mA about 40 ms (pause > 100 ms) about 4% of the set limiting value ± 1% of full scale value
Transmission behaviour	Accuracy Current influence Frequency influence Phase angle influence Temperature range Temperature influence Influence of aux. Load influence External magnetic field influence Residual ripple Setting time No load voltage Current limitation Test voltage Note	+/- 0.5% (with power factor +/- 0.5% in the range >25% of the apparent power $P_s = U \times I_{\text{Nominal}} \times 1.732$, with apparent power <25% is the accuracy +/- 1%, under 10% of the apparent power no measurement of the power factor) < 0.5 % with 0.15 – 2-fold rated current < 0.3% in the frequency range < 0.5 % at +/- 90° -15 to +20 to +30 to +55 °C < 0.2% at 10 K no no no (up to 400 A/m) < 100 mVss about 200 ms (power factor about 600 ms) max. 24 V max. twice with over amplification 4 kV between output to auxiliary voltage, 5.2 kV between input to output and input to auxiliary voltage, 2 kV between limit value or impulse output to output The UBS interface is galvanically connected to the outputs
Regulations	EMC Mechanical strength Electrical safety Accuracy, overload Separation Air and leakage paths Method of protection Connection	DIN EN 61326 DIN EN 61010 Part 1 DIN EN 61010 Part 1 Housing protection insulated, protection class II, with working voltage up to 600V (mains to neutral wire) degree of pollution 2, measurement category CAT III DIN EN 60688 DIN EN 61010 Part 1, 3.52 kV 50 Hz 10 sec. and 5.2 kV 50 Hz 10 sec. DIN EN 61010 Part 1 DIN EN 60529 housing IP40, terminals IP20 DIN 43807
Auxiliary voltage	Parts of wide area network	10 – 30 V AC + DC, 5 VA or 60 – 265 V AC + DC, 5 VA
Weight		600g
Dimensions		

MÜLLER 
ZIEGLER Elektrische Messgeräte

MÜLLER + ZIEGLER GmbH & Co. KG, Industriestr. 23, D-91710 Gunzenhausen
Tel. +49 (0) 98 31.50 04 0, Fax +49 (0) 98 31.50 04 20

<http://www.mueller-ziegler.de> , e-mail: info@mueller-ziegler.de

Fitting Snap fastenings onto standard rails 35 mm as specified in DIN EN 60715. The equipment is suitable for tight on tight assembly, however, with ambient temperatures of $>45^{\circ}\text{C}$ a distance apart of 10 mm is recommended. The assembly location should, if possible, be free from vibration and should not exceed an ambient temperature of 55°C .

Electrical Connection **The regulations on the building of electrical equipment should be observed.**

As specified in DIN 43807, with threaded terminal ends max. 4 mm².

When connecting the input quantity current the direction of the current should be noted, for applications with current converters the current rectifier dependent primary connection K and L as well as the secondary connection k and l. When connecting the input quantity voltage the assignment to the current connection is important which means in the phase in which the current converter lies the respective terminal of the voltage connection must also lie.

Output load independent: If several plotters such as switching and control equipment, recorder, etc. are connected with current input then these should be connected in series with the output of the measuring transmitter (take care of the polarity). The maximum working resistance of 500 Ohms, including the feeder, must not be exceeded.

Output voltage independent: If several plotters such as switching and control equipment, measuring equipment, recorders, etc. with voltage input are connected then these should be connected in parallel with the output of the measuring transmitter (take care of the polarity). The maximum load of 20 mA may not be exceeded.

Note If all current and voltage outputs are used at the same time then the voltage output is loaded with a maximum of 1 mA, or the complete output current of the 8 outputs may not exceed a total of 84 mA.

Protection The auxiliary voltage connection is protected in the equipment with a 1 A fuse.

Calibration The measuring converter is calibrated in works. A new calibration should be done every 2 years in the manufacturer's works.

Configuring The measuring converter is configured in works if the necessary data is known. The equipment can be reconfigured at any time. It is only necessary to have the corresponding software for this (accessory) and a PC. The measuring converter and the PC should be connected by means of a USB cable (accessory). The auxiliary voltage should be connected to the measuring converter. The different configuration possibilities of the inputs and outputs are programme driven. The software (accessory) for configuring is delivered on a CD. The software can be installed under Windows 2000, Windows XP (32-/64-bit) and Windows Vista (32-/64-bit).

Note, **The UBS interface is galvanically connected to the outputs**

Connection **3-/ 4- wire three phase alternating current, of any load.**
(inputs and outputs that are not used remain blank)

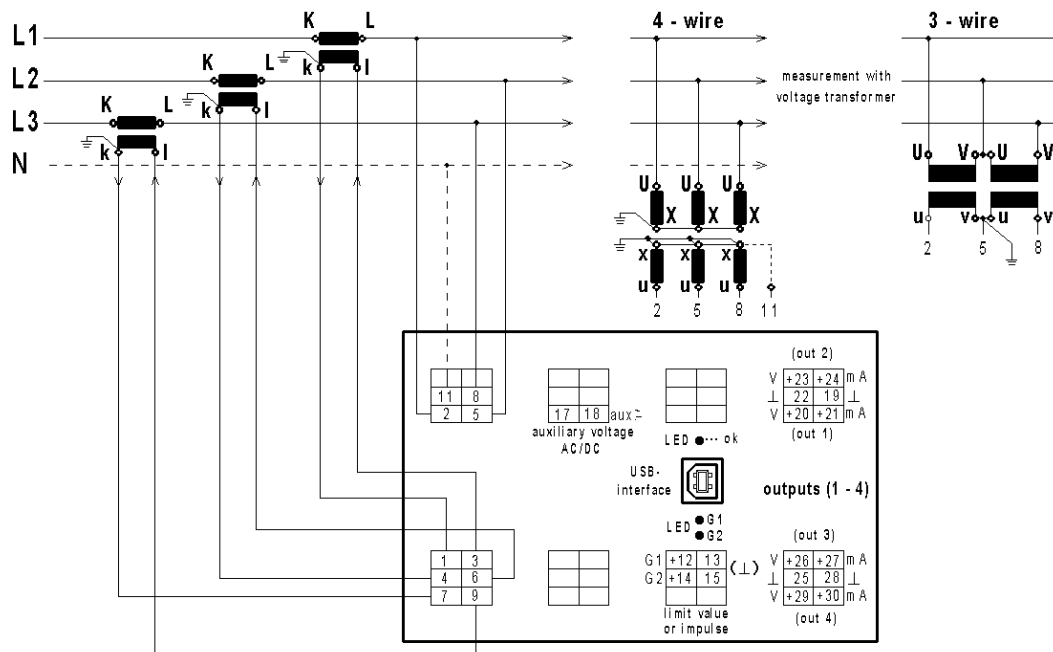

MÜLLER 
ZIEGLER Elektrische Messgeräte

MÜLLER + ZIEGLER GmbH & Co. KG, Industriestr. 23, D-91710 Gunzenhausen
Tel. +49 (0) 98 31.50 04 0, Fax +49 (0) 98 31.50 04 20

<http://www.mueller-ziegler.de> , e-mail: info@mueller-ziegler.de

Connection 3- wire three phase alternating current, of same load.
(inputs and outputs that are not used remain blank)

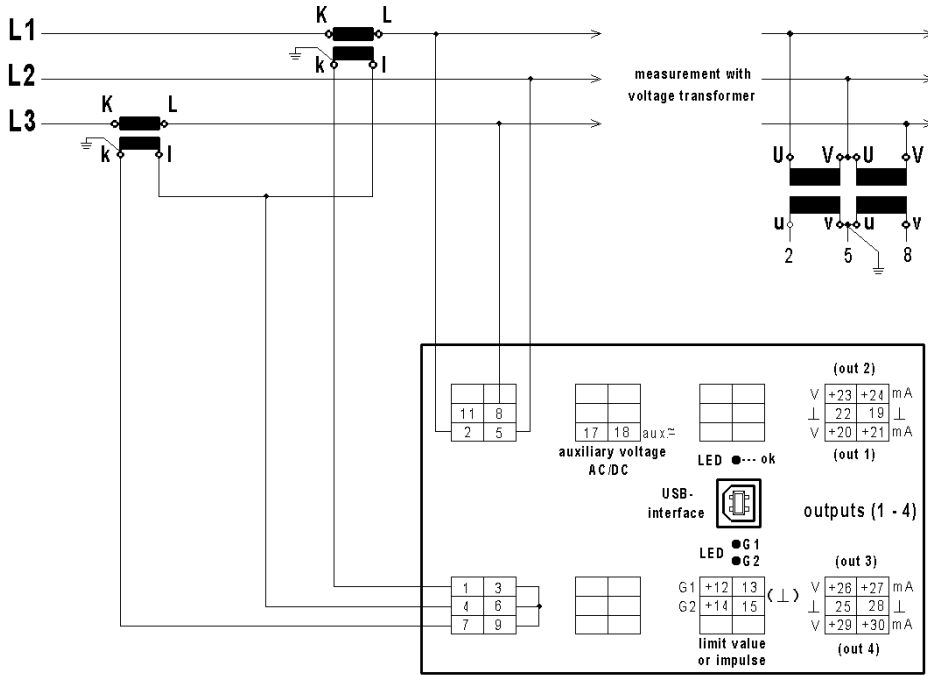

Connection 3-/ 4- wire three phase alternating current, of same load.
(inputs and outputs that are not used remain blank)

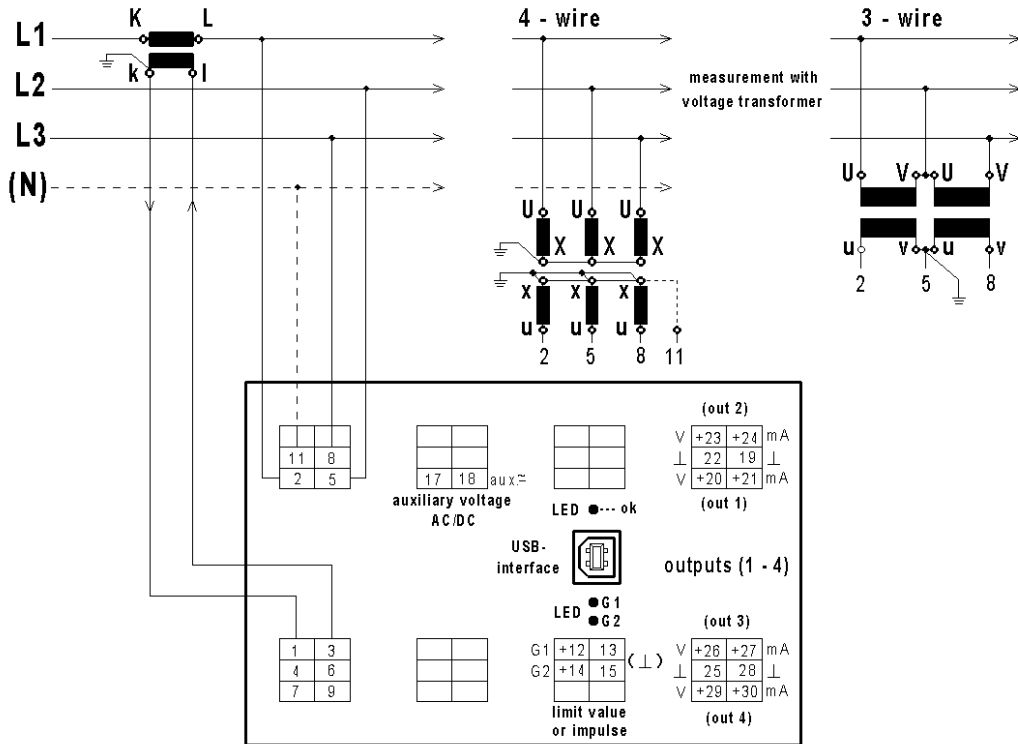

MÜLLER + ZIEGLER GmbH & Co. KG, Industriestr. 23, D-91710 Gunzenhausen
Tel. +49 (0) 98 31.50 04 0, Fax +49 (0) 98 31.50 04 20

<http://www.mueller-ziegler.de> , e-mail: info@mueller-ziegler.de

Connection Alternating current
(inputs and outputs that are not used remain blank)

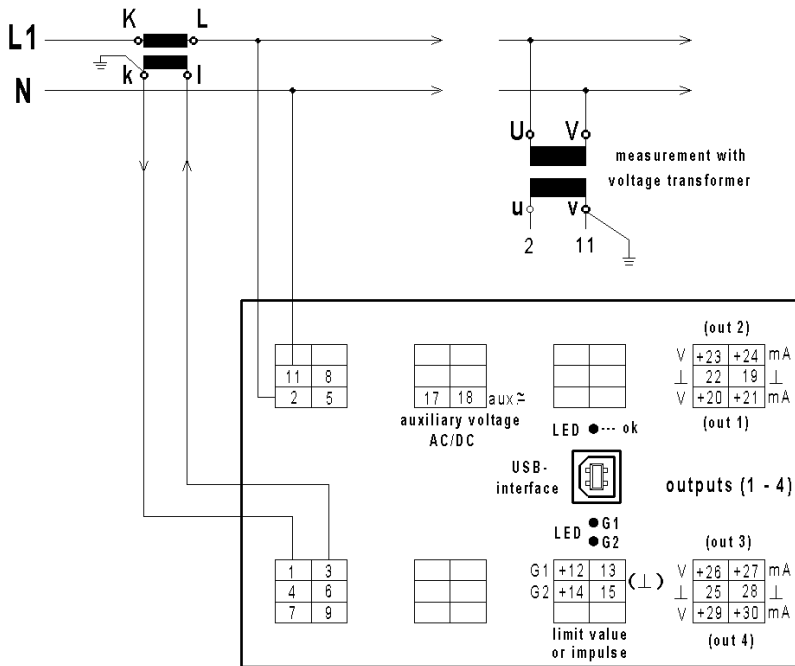

Connection Limit value or impulse G1 and G2

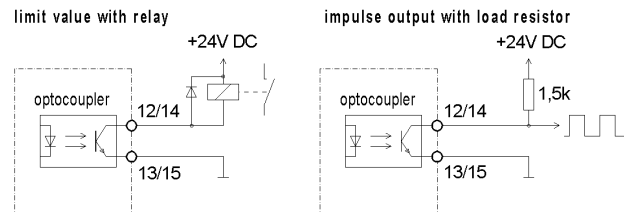

Warning
Servicing
Note

Before beginning any work on or in the equipment it should be disconnected from the mains or switched off.
The equipment requires no maintenance when it is used properly.
Repair and servicing work must only be carried out by trained technical staff.

MÜLLER 
ZIEGLER Elektrische Messgeräte

MÜLLER + ZIEGLER GmbH & Co. KG, Industriestr. 23, D-91710 Gunzenhausen
Tel. +49 (0) 98 31.50 04 0, Fax +49 (0) 98 31.50 04 20
<http://www.mueller-ziegler.de>, e-mail: info@mueller-ziegler.de