

MEASURING TRANSDUCERS FOR CURRENT AND VOLTAGE (EFFECTIVE)

leff-MU, Ueff-MU

General information	This operating manual is included with the equipment as standard. It contains the information required for correct usage. It is aimed at trained personnel and specialist staff who are familiar with the assembly, installation and commissioning of the product described here. If additional information is required, further details can be requested by the address given below.	
Conformity	This equipment conforms to the requirements of the Directive from the Council of the European Community on the harmonisation of the member states regarding electromagnetic compatibility, EMC Directive 2004/108/EC, as well as Low Voltage Directive 2006/95/EC.	
Application	The measuring transducers leff-MU and Ueff-MU serve to convert a current or a voltage of any curve shape into a load-independent direct-current and direct-voltage signal. The calibrated double-outputs can be switched over between 0-20 mA / 0-10 V and 4-20 mA / 2-10 V.	
Function	The measurable variable gets via an input protective circuit to the effective value rectifier. Crest factors (ratio of peak value to effective value) up to the value "4" can be well processed. The direct voltage gained is isolated electrically from the output by means of an optocoupler. A secondary amplifier causes the direct current and the direct voltage to be impressed. Both outputs are no-load and short-circuit resistant. Any connection between both outputs will be unacceptable. An auxiliary voltage will be required for all types.	
Technical data		
Input	Input quantity	DC and AC of any curve shape
	Rated values	1 mA up to 0.5 A, relative voltage drop 60 mV (type leff-MU) 0-60 mV up to 0-600 V, $R_i = 100 \text{ k}\Omega$ up to 1 V, >1 V 100 k Ω /V, 2 M Ω max. (type Ueff-MU)
	Rated frequency	DC/40-200 Hz, option DC/40-1000 Hz
	Overload permanent	Current 2-fold, voltage 5-fold, max. 830 V
	Surge overload	Current 20-fold 1 sec., voltage 2-fold 1 sec.
Output	Output quantities	double-output
	Rated values	0-20mA /0-500 Ohm of load and 0-10V max. load 10 mA as well as 4-20mA /0-500 Ohm of load and 2-10V max. load 10 mA front-laterally switchable (aux. will be required) -Frequency module - a value of 0 – 5 Hz up to 0 – 10 kHz <ul style="list-style-type: none"> ○ „Open-collector“ NPN, max. 30V 100 mA loadable, impulse/break 50/50 % ○ Square wave signal 5V, max. 10 mA loadable, impulse/break 50/50 %
Dynamic system behaviour	Accuracy	+/- 0,5 %
	Crestfactor	4 with 0,5 % error
	Frequency influence	< 0,5 %
	Temperature range	-15°C up to <u>+20°C up to +30°C</u> up to +55 °C
	Temperature influence	< 0,2 % at 10 K
	Influence of aux.	none
	Load influence	none
	External magnetic field influence	none (up to 400 A/m)
	Residual ripple	< 30 mV _{ss}
	Response time	< 300 ms (with frequency module < 400 ms)
	No-load voltage	max. 24 V
	Current limitation	max. 2-fold in case of saturation
	Testing voltage (working voltage up to 300V)	4 kV between input and output, input and aux., output and aux.
	Testing voltage (working voltage up to 600V)	4 kV between output and aux., 5,2 kV between input and output aux. 230 VAC and 110 VAC: 4 kV between input and aux. aux. 24 VDC, 6-30 V AC/DC and 36-265 V AC/DC: 5,2 kV between aux. and input



MÜLLER + ZIEGLER GmbH & Co. KG, Industriestr. 23, D-91710 Gunzenhausen

Tel. +49 (0) 98 31.50 04 0, Fax +49 (0) 98 31.50 04 20

<http://www.mueller-ziegler.de> ,email: info@mueller-ziegler.de

Adjustment	After taking off the plexiglass cover it is possible to adjust with the potentiometer which is named "SPAN" the final value and with the potentiometer which is named "ZERO" the zero-point (zero point elevation only). With the slide switch the output can be changed over between "LIVE ZERO" (4-20 mA/ 2-10 V) and "ZERO" (0-20 mA/0-10 V).	
Regulations	EMC Mechanical strength Electrical security	DIN EN 61326 DIN EN 61010 part 1 DIN EN 61010 part 1 Housing all insulated, protection class II, at a working voltage up to 300V (network to neutral conductor) degree of pollution 2, overvoltage category CAT III at a working voltage up to 600V (network to neutral conductor) degree of pollution 2, overvoltage category CAT III DIN EN 60688 DIN EN 61010 part 1, 3,52 kV 50 Hz 10 sec. and 5,2 kV 50 Hz 10 sec. DIN EN 61010 part 1
	Accuracy, overload Separation Air gaps and creep distances System of protection Connection	DIN EN 60529 housing IP30, terminals IP20 DIN 43807
Auxiliary voltage		230 V AC \pm 20 %, 45-65 Hz, 2,5 VA
	Option	<ul style="list-style-type: none"> • 110 V AC \pm 20 %, 45-65 Hz, 2,5 VA • 24 V DC, -15 % bis +25 %, 2 W, (EMC DIN EN 61326 class A) • 6-30 V AC + DC or 36-265 V AC + DC, 2 VA, (EMC DIN EN 61326 class A)
Weight		170g
Dimensions		

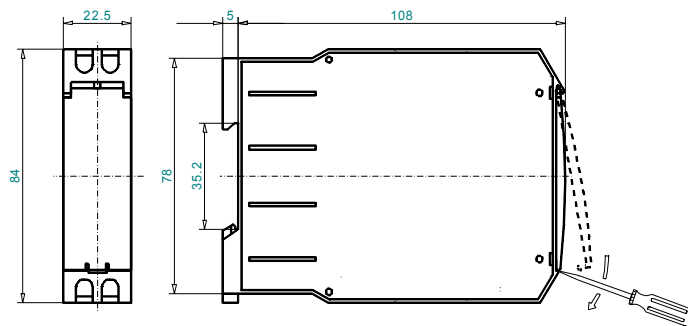

Installation Attachment snap-on mounting according to DIN EN 50 022
Electrical connection threaded terminal end 4 mm² max.

Connection

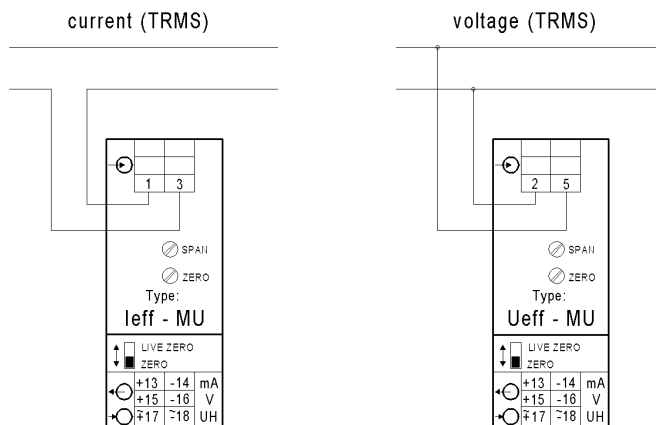

Transducers with frequency module have no further outputs and no "LIVE-ZERO"-switching.
At the clamps +13 and -14 the frequency output is available.

Warning! Before starting any work on or in a device, it must be disconnected from the mains or switched to a voltage-free state.

Maintenance The device is maintenance-free when used correctly.

Caution! Servicing or maintenance work must only be carried out by trained specialist personnel.

